

● Usage

**Machines & Tools**

- Use a soldering gun
- Our thermal deposition machine with temperature control & various punches

**Insertion method**

Thermocompression method

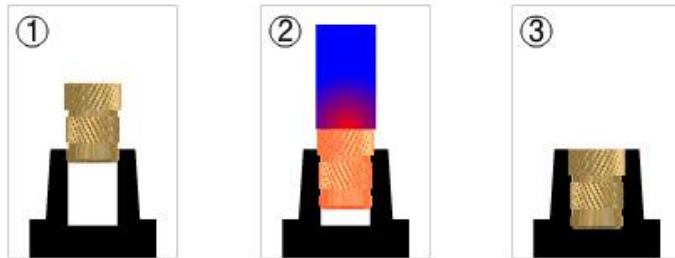

①Set insert nut→②Termocompression→③Complete

**Parent material size**

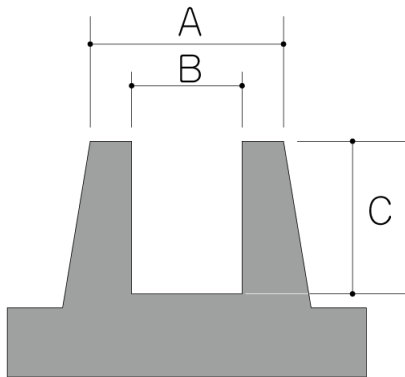

A: See the below table "A."  
 B: See the below table "B"  
 C: Total length "L" + 0.05mm or more

**Note at use**

Make decision to use after test because various things are considered about the hole shape of the parental material.

● Strength Reference

Part No.	ABS		Polycarbo	
	Torque(N-m)	Tension(N)	Torque(N-m)	Tension(N)
UD-43001	1.6	1471	2.2	1667
UD-43501	2.6	2648	3.4	3423
UD-44001	3.3	2844	3.9	3852
UD-45001	6.5	3726	7.8	5198
UD-46001	8.8	5394	11.8	6865

● Dimensions Table

**UDIV (UltrasertIV)**

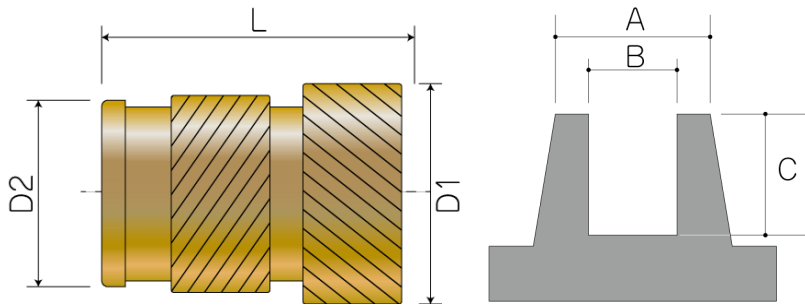

C : Insert used total length L plus 0.5 mm or more.

**Thread M2×0.4**

Part No.	D1	D2	L	A	B	Pieces / Box
UD-42001	3.6	3.1	4.0	6.0	3.2	8,000

**Thread M2.6×0.45 (M2.5×0.45)**

Part No.	D1	D2	L	A	B	Pieces / Box
UD-42601	4.6	3.9	5.7	7.0	4.0	3,000

**Thread M3×0.5**

Part No.	D1	D2	L	A	B	Pieces / Box
UD-43030	4.6	3.9	3.0	7.0	4.0	5,000
UD-43040	4.6	3.9	4.0	7.0	4.0	5,000
UD-43050	4.6	3.9	5.0	7.0	4.0	4,000
UD-43001	4.6	3.9	5.7	7.0	4.0	3,000

**Thread M3.5×0.6**

Part No.	D1	D2	L	A	B	Pieces / Box
UD-43501	5.6	4.7	7.1	8.5	4.8	2,000

**Thread M4×0.7**

Part No.	D1	D2	L	A	B	Pieces / Box

UD-44058 Part No.	6.4 D1	5.5 D2	5.8 L	9.5 A	5.6 B	1,500 Pieces / Box
UD-44065	6.4	5.5	6.5	9.5	5.6	1,000

UD-44001	6.4	5.5	8.2	9.5	5.6	1,000
----------	-----	-----	-----	-----	-----	-------

### Thread M5×0.8

Part No.	D1	D2	L	A	B	Pieces / Box
UD-45058	7.1	6.3	5.8	11.5	6.4	1,500
UD-45001	7.1	6.3	9.5	11.5	6.4	800

### Thread M6×1.0

Part No.	D1	D2	L	A	B	Pieces / Box
UD-46065	8.6	7.9	6.5	14.0	8.0	800
UD-46095	8.6	7.9	9.5	14.0	8.0	500
UD-46001	8.6	7.9	12.7	14.0	8.0	400

### Thread M8×1.25

Part No.	D1	D2	L	A	B	Pieces / Box
UD-48001	10.4	9.5	12.7	17.5	9.6	300

### Thread M10×1.5

Part No.	D1	D2	L	A	B	Pieces / Box
UD-41001	11.8	11.0	12.7	23.5	11.2	800

### FUIV (Flange UltrasertIV)

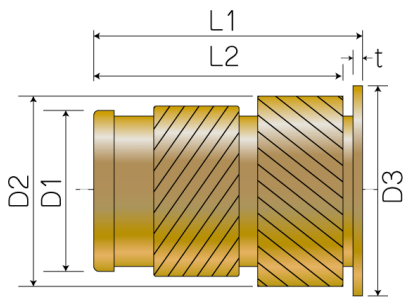

Thread	Part No.	D3	D2	D1	L1	L2	t	Pieces / Box
M3×0.5	FU-43001	5.5	4.6	3.9	6.3	5.7	0.6	3,000
M4×0.7	FU-44001	7.0	6.4	5.5	9.0	8.1	0.9	1,000
M5×0.8	FU-45001	8.0	7.1	6.3	10.6	9.5	1.1	600
M6×1.0	FU-46001	9.5	8.6	7.9	14.0	12.7	1.3	300
M8×1.25	FU-48001	12.0	10.4	9.5	14.0	12.7	1.3	1,000